

Installation and Maintenance Manual

Sliding Gate Operators

Inbuilt Models: GDS 450P I & 630P I Range

Made in Australia from Australian & quality imported components

MOVITRAC B



B Bennet Avenue Melrose Park SA 5039
Phone 08 8374 3466

A.B.N. 62 059 806 405
July 2014



N14870

Abbreviated Installation Instructions

(For those who don't have time!)

Sliding Gate Operators

PLC 450, 630 Range

Made in Australia from Australian & quality imported components

MOVITRAC B

Place operator in correct position (Pinion wheel to be parallel to the gate and stepped out to allow for width of rack once it is mounted onto the gate frame). Mark out fixings and fix operator to the concrete pad.



Fix rack to the gate frame keeping 1mm-2mm clearance between the rack teeth and Pinion wheel

Once the rack is fixed move the gate and sight the rack moving over the pinion wheel, check that most of the pinion wheel meshes with the rack. Make sure rack runs freely over the pinion wheel, any tight spots should be corrected by adjusting the rack height. Check the operator is firmly bolted down to the concrete pad.



Ensure stops are installed on the gate for the fully closed and fully open positions.



Connect Power supply (If not done already). Turn on Power.

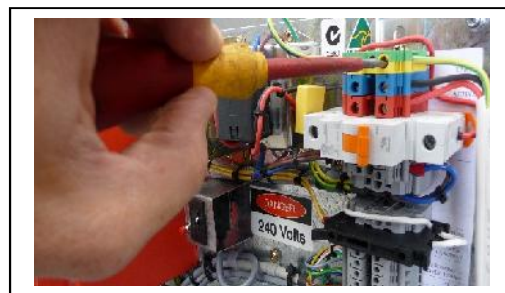

To commission the gate, move the gate approximately 1m from the fully open position and tighten the knurled wheel (Clockwise) engaging the clutch assembly



Press the red commissioning button located next to the inverter and mode switch. (note-there should not be a present input on the open terminal from field wiring, this will prohibit the gate from closing, a momentary pulse is all that is required).

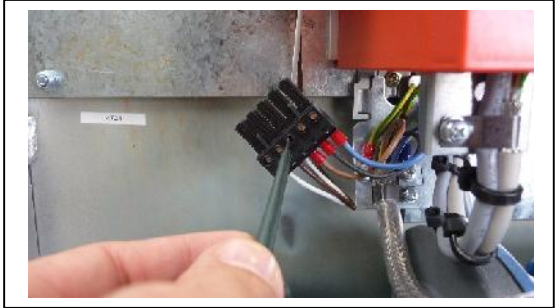

Ensure the direction the gate first travels is toward the fully open position, if the gate first travels towards the closed position then turn the power off and reverse two of the motor wires at the inverter terminals.



For the commissioning process the gate will fully open, then 2 seconds later it will automatically fully close. During this commissioning the PE beam and Door inputs are not required. Once the gate is commissioned (gate has fully closed) the gate distance is in the memory of the inverter, the Door and PE beam inputs need to be connected.

Give a pulse input to the open terminal and the gate will open (note. The gate will perform one slow speed operation to confirm the gate opening distance and will then be ready to run at full speed).

Select desired mode of operation via the thumb wheel selector switch (please refer to the installation manual for mode functions).



If inverter settings require adjusting for example Opening, closing speeds, ramp times etc. please refer to the installation manual for instructions and parameter description list.

CONTENTS

Section No:		Page No:
	Abbreviated Installation Instructions	2-3
1	Safety Precautions	5
2	General Information	6
3	Wiring Requirements	6
4	Installation Details	6-11
	Electrical Cabling	
	Mechanical Installation	
	Plan view of installation / Operator dimensions	
	Electrical Connections	
	Variable Speed Drive Unit	
	Variable Speed Drive Unit - Key Pad Operation	
	Function Factory Setting	
	Parameter Settings	
	Gate Direction Set-Up	
	Commissioning	
5	Fault Finding	12-13
6	Control diagram	14
7	Maintenance	15
8	Warranty	16

1. SAFETY PRECAUTIONS



WARNING! FAILURE TO FOLLOW THESE SAFETY PRECAUTIONS AND INSTALLATION INSTRUCTIONS COULD RESULT IN INJURY OR DEATH AND/OR DAMAGE TO PROPERTY AND EQUIPMENT.

- Appropriately licensed and competent personnel only should install the automation equipment.
- The operators are designed specifically to open and close sliding gates or doors and should not be used for any other purpose.
- Before commencing installation, read through this installation manual.
- Check that the operator and controls are in new condition and have not been damaged in transit.
- Check the gate or door and it's associated support posts and walls to protect against shearing, compression and other various traps which could cause serious injury or death. Take into consideration the general installation and surrounding environment.
- Check the gateposts or mounting structure has the necessary strength and rigidity to support the operator and the load of the opening and closing gate motion.

CAUTION!



Always incorporate the appropriate Photo Electric Cells, Induction Loops and any other safety devices to protect both equipment and personnel. Extra caution should be employed when using operator in auto close mode.

- Display any necessary signs to indicate any danger areas and automatic operation of the gate or door.
- The operators are not designed to be used in any hazardous areas or areas subject to flooding etc.
- All electrical connections and wiring must be performed with AS/NZS 3000-2007 as the guidelines. (Or its counterpart for other countries outside of Australia and New Zealand)

WARNING! ELECTRICITY CAN KILL

- The manufacturer of the automation equipment is not responsible for the damage which may be caused to either the operator, gate or door and any other person or equipment when: -
 - Wrong or poor installation practices were performed.
 - No or inadequate safety devices were used.
 - Either the surrounding structure or the gate or door strength and rigidity was not sufficient for the task in hand.
 - Inefficient locking devices were employed.
 - Poor maintenance on the equipment.
 - Any other circumstances beyond the manufacturers control.
- Isolate power before attempting any maintenance, qualified personnel only to carry out maintenance
- Only original spare parts are to be used should there be a requirement for them.
- Keep loose clothing and hands clear of the gate whilst in operation or potentially able to be operated.
- The installer should provide all information concerning the use of the automation equipment as well as instructions regarding the manual override and maintenance procedures to the users of the system.

2. GENERAL INFORMATION

General Information regarding the “PLC” type operators

- These operators incorporate a combined Inverter/PLC in one for the driving and control of the gate.
- There is no need for any limit switches, proximity switches or motor encoders as the PLC control system utilises ‘Advanced positioning control’, meaning the PLC always knows where the gate position is as it is driving.
- The initial commissioning procedure sets this ‘advanced positioning control’ and therefore it is important to follow the procedure to ensure the correct gate opening distance is set into the memory of the PLC control.
- If the commissioning procedure fails, (eg the gate stops are in the wrong position and a incorrect distance is set) you will need to contact Gate Drive Systems Australia and quote the Parameter 401 number of the inverter unit to obtain another set up code)
- **IMPORTANT:** The commissioning procedure does not require the cover to be on. However once the gate is commissioned the cover will need to be fitted and the manual release door closed. This then ensures that the door safety switch is closed and allows for correct operation.
- Whenever the manual release door is opened or the power is taken off the operator, the gate operator will automatically run slow for the first operation to allow the positioning system to realign itself. After realignment, the gate will function normally.
- As can be seen from the commissioning procedure, the commissioning is as easy as providing an input to the controller, the operator will do it all for you!
- Happy Automating!

3. WIRING REQUIREMENTS

- 240v 10A non earth leakage protected power supply where operator is mounted.
- Low voltage cables from operator for access control. (Shielded cable if over 8m runs).

4. INSTALLATION DETAILS

After reading the previous sections in this manual, and having checked for suitable installation, proceed as follows:-

Electrical Cabling

- A suitably rated Isolator and 240v power supply should be available near to where the gate operator is to be mounted.
- Conduits and cabling preferably to enter through baseplate 'knockout' hole. The following dimensions will provide measurements for the positioning of Conduits and the appropriate position for the mounting of the operator, whether a GDS 450PI or a GDS 630PI.

Mechanical Installation

- Ensure gate rolls easily and has been installed in a manner where there is no excessive friction or binding occurring.
- A concrete base approximately 600mm long x 300 wide x 300mm deep should be laid where the gate operator is to be located.
- **IMPORTANT** ensure there are gate stops firmly installed in the fully open and closed positions. These stops need to be engineered and installed such that they will be strong enough to stop the gate should the gate fail to stop at any time.
- Remove the gate operator cover and position mounting plate and operator in the approximate mounting location.
- Hold the rack next to the gate bottom rail and locate the operator the correct distance away from the gate rail (finer adjustment can be made after).
- Dynabolt or chemical anchor the bottom mounting plate to the concrete mounting pad using 12 x 100mm fixings.
- Unscrew anticlockwise the manual disconnect knurled knob so the drive gear free wheels.
- Fix the rack to the gate rail ensuring there is approximately 1mm - 2mm gap between the meshing of the teeth of the rack and the drive gear (no more). Move the gate by hand from one end to the other while checking that the rack is meshing correctly with the drive gear on the operator. Check also that the rack is centred around the middle of the teeth on the drive cog – tighten the mounting plate nuts.

Plan View of Installation / Operator Dimensions

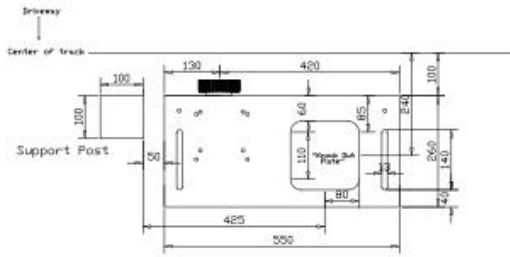

- NOTES:
- THESE MEASUREMENTS ARE ONLY APPLICABLE WHEN USING A 100x100 GATE FRAME
 - THIS DRAWING IS FOR A GATE THAT OPENS TO THE LEFT WHEN LOOKING FROM THE ROAD INTO THE PROPERTY
 - WITH THIS GATE OPENING SCENARIO, THE CENTER POSITION OF THE CONDUIT ENTRY IS 425mm FROM THE SUPPORT POST AND 240mm FROM THE CENTER OF THE TRACK

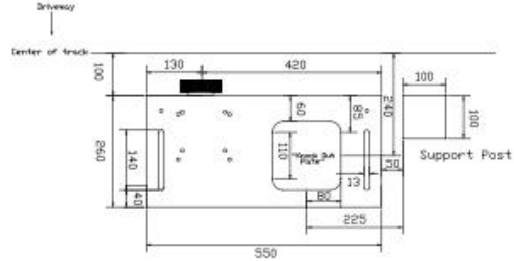

- NOTES:
- THESE MEASUREMENTS ARE ONLY APPLICABLE WHEN USING A 100x100 GATE FRAME
 - THIS DRAWING IS FOR A GATE THAT OPENS TO THE RIGHT WHEN LOOKING FROM THE ROAD INTO THE PROPERTY
 - WITH THIS GATE OPENING SCENARIO, THE CENTER POSITION OF THE CONDUIT ENTRY IS 225mm FROM THE SUPPORT POST AND 240mm FROM THE CENTER OF THE TRACK

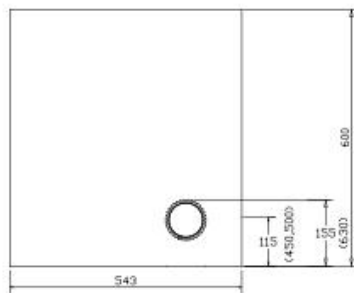

BACK VIEW

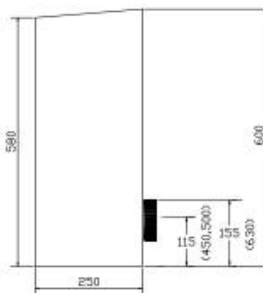

SIDE VIEW

Electrical Connections

- A 240v 10 amp Non Earth leakage protected power supply is required to power up the unit

Electrical DIN rail terminal connections are as detailed below

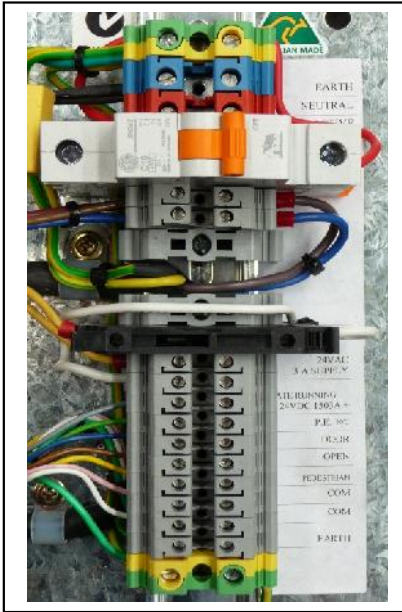

EARTH
NEUTRAL
ACTIVE
CIRCUIT BREAKER
Active (Filtered)
Neutral (Filtered)
Fuse (for 24v supply)
24V 3A Supply
Gate running Output } -
Gate running Output } + 24V 150mA
PE (normally closed)
Door (not for field connections)
OPEN/CLOSE
Pedestrian
COMMON (for Pedestrian, Open/Close, P.E and Door connections)
COMMON (for Pedestrian, Open/Close, P.E and Door connections)
EARTH

Please Note: That for field wiring connections, screened cable should be used where the length of the cable run exceeds 8 metres. Screen is to be terminated into the earth terminal`.

Input / Output functions

Pedestrian Input: The pedestrian input allows for the gate to be opened to a certain % of the full gate opening distance (20%-80% range). The % can be adjusted via the keypad from the N22 setting (see notes that follow).

Open/Initialise Input: This input is used to commission the drive, and also used to open and close the gate.

Door input: The door input is a safety function due to the operator having a manual release. Whenever the door is opened or the cover removed the next operation will be performed at slow speed so the inverter can reconfirm the stop positions. This averts the gate running at full speed into open and closed stop positions.

NC Safety Beam: The n.c safety beam input allows for the connection of safety devices (loops, PE beams, and other such equipment) which aid in the prevention of injury and damage to personnel and equipment upon the gate closing.

10k Ohm Potentiometer: This has been supplied to allow an adjustment of 0-5 seconds pre-warning time before gate operation commences.

Gate Running Output: Whenever the inverter is signalled to operate it provides an output (24vDC 150mA), which can be used to run other equipment. Where greater current draw is required or unsure of current draw it is recommended to connect a relay with which to operate auxiliary equipment.

Operating Modes

The thumbwheel selector switch is used to select the operation mode which best suits the customers purpose, the details of the operational modes are as follows:

Mode “0”

#Auto close, (1-120 seconds, set by the knob on the front of the keypad, fully clockwise is 120 second auto close time.)

#PE auto close, (meaning that when the gate is fully open and the photo electric cell beam is broken and then made again the gate will close straight away)

#Multi-user, (meaning that the control circuitry will ignore any other input signals once the gate is opened and will only close with the auto close.)

Mode “1”

#Manual operation, (meaning input to open and input to close) except, when closing and the PE is broken the gate will open up fully but will then auto close once the PE's are cleared.)

Mode “2”

#Auto close, (meaning once the gate has opened the gate will close automatically once the set time has expired) (The auto close time is set by the knob on the front of the keypad, fully clockwise is maximum time, 120 seconds)

#No PE auto close, (meaning the gates will not close even if the PE cell beam is broken and made again.)

#No Multi-user, (meaning the auto close time can be overridden by another input to close the gates)

Mode “3”

#Manual operation, (meaning input to open, input to close) If PE beam is broken while gate is closing the gate will reopen and wait on another input to close.)

(The **Pedestrian** input will operate as per the open input for the above operating modes).







Variable Speed Drive Unit

- The variable speed drive unit will, ramp up the speed of the operator, run at a predetermined fast speed and then ramp down prior to closing. For approximately the last 500mm the gate will drive slowly into the stops.
- The acceleration and deceleration times have been set in the factory for a normal installation but can be changed if necessary. Similarly, the speed that the gate operates at has also been set but can be changed.

Variable Speed Drive Unit – Key Pad Operation

- The following diagram (Figure 1) shows the keys on the keypad, which is used to select the various functions, please refer to these when reading further instructions.

Figure 1.

 	Use UP / DOWN to select symbols and change values.
 	ENTER/OUT to activate and deactivate the symbols or parameter menus
	Press "RUN" to start the drive.
	"STOP/RESET" is used for resetting faults and for stopping the drive.

The diagram below (Figure 2) corresponds to what is shown on the keypad of the SEW variable speed drive (this keypad is removable).

Figure 2.



Function Factory Settings

- Acceleration ramp time 5 sec
- Deceleration ramp time 4 sec
- Maximum speed 4000 rpm (For 750's = 640mm/sec, for 550's = 490mm/sec)
- Opening Speed 3640 rpm (For 750's = 580mm/sec, for 550's = 440mm/sec)
- Opening and closing slow speed 600 rpm (For 750's = 100mm/sec, for 550's = 75mm/sec)
- Closing Speed 3000 rpm (For 750's = 480mm/sec, for 550's = 360mm/sec)
- The motor start-up function has been pre-set in the factory and should not need altering

Parameter Settings

- | Par | Nxx | |
|----------|-----|---|
| • Pt 39 | | Input Status |
| • Pt 59 | | Output Status |
| • Pt 80 | | Fault memory (records the previous faults which occurs with the inverter) |
| • Pt 136 | | PE stop time (0.5 s) |
| • | N11 | Opening speed (3640 rpm) |
| • | N13 | Closing speed (3000 rpm) |
| • | N21 | When set to formulae and powered off and on will reinitialise the gate |
| • | N22 | Pedestrian opening position (% of full opening position max 80%) |
| • | N23 | Opening and closing slow speed (600 rpm) |
| • Pt 400 | | Gate counter, maximum 5000 (500,000 operations) Note. 100 gate operations will be recorded as 1 on the inverter counter). |
| • Pt 401 | | Internal serial number for recalibration |
| • Pt 450 | | low current setting (usually 60 %) |

Selecting a Function

- To select a function use the up/down arrow keys to select corresponding symbol for desired function.
- An LED will light up the symbol and the display will show the programmed settings for that function.

Setting Function Values

- Having selected the desired function; to enter or change a setting press the enter key. The display will flash.
- A value for the function can now be entered or changed using the up/down arrow keys.
- To confirm the value for the desired function press the enter key, this will set the value, then press the out button, this will return you to the previous screen.

Gate Direction Set-Up

- It is important that the gate is set up to operate correctly for the opening and closing cycles.
- When the gate is closing a minus sign will be displayed on the screen when monitoring the RPM
- On first pulse to open/commission the gate should always open first
- If the operation is not as above, two motor wires need to be swapped over.

Commissioning

- Tighten knurled knob at back of slider, very firmly by hand so gate will drive.
- Power up board and with gate in the half way position, press transmitter or manual control switch (manufacturer has provided a push button for open/closing/commissioning next to PLC inverter) so operator drives gate. (Note. for commissioning, a momentary pulse is all that is required)
- The first pulse must always open the gate, if it does not, then turn off the power and reverse 2 of the motor wires.
- Allow the gate to fully open onto the open stop. The gate will then automatically start closing at slow speed; do not interrupt this auto commissioning cycle as it is determining the gate opening distance.



CAUTION! Ensure vehicles and personnel do not get in the way of the moving gate as both the photoelectric cells and door inputs are bypassed during commissioning.

- Once the gate reaches the fully closed position the inverter will automatically switch the power off to the motor.
- The photoelectric/safety devices and door switch wiring will now need to be operational in order for the operator to function.
- Install cover onto operator with 4 fixing screws and close manual release door.
Press the transmitter or operate the access control, the gate will fully open at slow speed to confirm the gate opening distance.
- Once the gate has reached the fully open position, the operator is now ready to operate at full speed
- A potentiometer has also been provided, which is found under the cover of the inverter, which can be rotated to adjust the gate operation pre-warning time (clockwise = minimum time = 0 second, and anticlockwise = maximum time = 5 seconds).
- Press the transmitter or manual control switch to now test the normal operation, i.e. ramp up, run at fast speed, ramp down and then slow speed into the open and closed stops.
- PLEASE NOTE: Each time the gate operator power is turned off or the manual release door is opened, the gate will run at slow speed to allow the controller to recalculate its position.
- Check that all safety devices work as designed.
- Provide full details to the owner concerning the operation and relevant maintenance and disconnection details in the event of a power failure.

5. FAULT FINDING

In the event that the operator does not function due to a fault or unmet condition, there is a simple and effective way of ascertaining where the probable fault may lie. As the inverter is a combination PLC that provides the logic for executing the running of the gate motor, the inputs and their status are very important. Understanding what each input does will help to clear or rectify any problem relating to the input. To see the status of the inputs, proceed to parameter 39 via the keypad (refer to section on 'keypad operation' for navigating your way there). The various strokes relate to the inputs, when the stroke is high it means the input is on, and when low, the input is off. This screen can therefore be used to ascertain what inputs are on or off, making the fault finding process much quicker.

Parameter 39 and 59 can be used for fault finding as shown below.

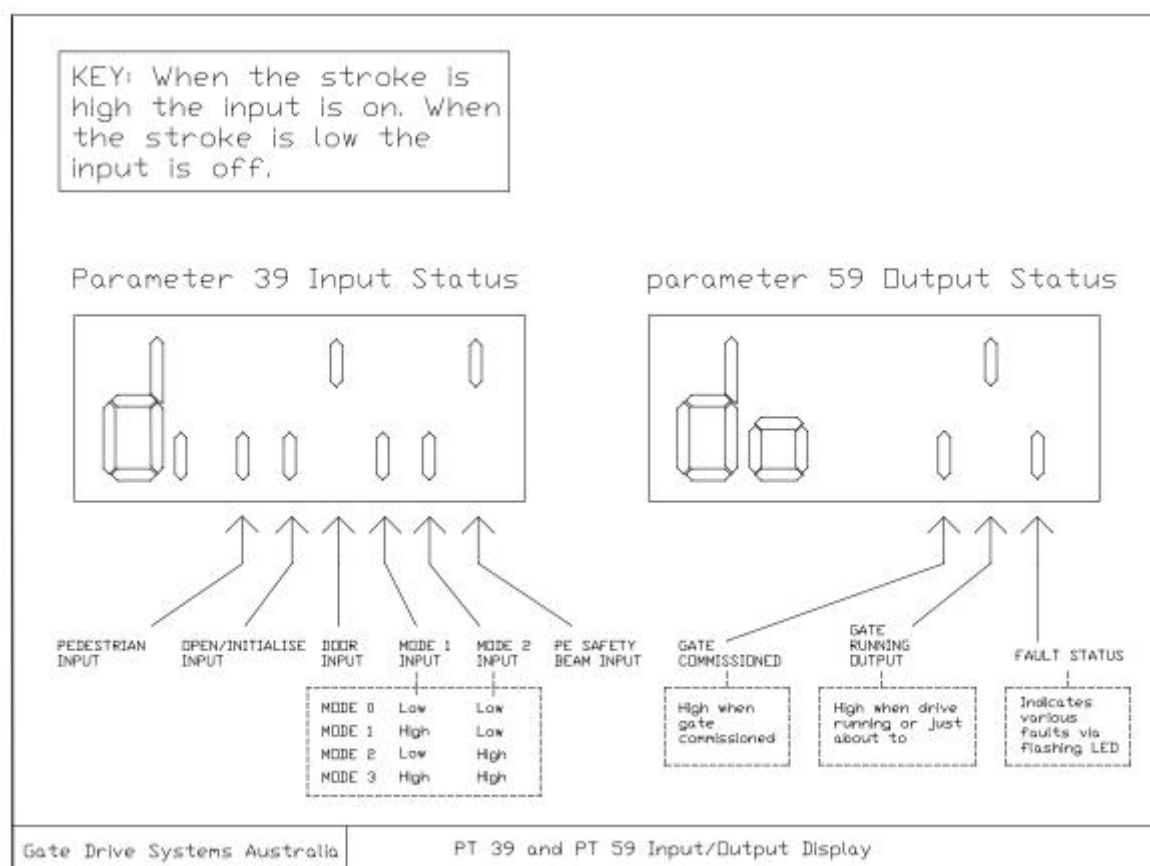

SEW Program with LED fault indication

The fault status right hand led segment in P 35 will move up and down so many times according to what state each input is in. Some earlier model operators had a red led mounted in the back plate of the operator so the status of the operator could be seen without taking the cover off.

No of flashes

Fault description

1 flash	Inverter fault other than fault 08
2 flashes	Gate fully open and with open input held so gate won't close
3 flashes	Gate fully open and with PE input fault so gate won't close
4 flashes	Operator manual release door open so gate won't operate
5 flashes	Gate at pedestrian open position and pedestrian input held so the gate will not close.
6 flashes	Gate will do next move at slow speed because gate travel Interrupted and previous run did not find the limit at the Correct position
7 flashes	Gate fully open and pedestrian input held so gate will not close.
8 flashes	F 08 speed monitoring fault, motor can't get to desired speed.

Check the following:

If unit is brand new, chances are the inverter has not been commissioned properly.
Check gate runs free in manual, track, wheels, guides, gate alignment.
Rack fitted correctly and meshing properly with pinion.
Clutch done up tight.
Clutch disks in good condition.
Track in good condition and no stones etc on or too close to track.
Both close and open stops in good condition.
If a brake motor, check to see if brake is releasing.
Check maximum speed and make sure opening speed
Does not exceed maximum speed.
If gate is extremely heavy, the ramp times may need to be
Increased to give the gate more time to reach its designated operating speed.
If gate is extremely heavy the low speed current setting may
To be increased. It can be adjusted from 60 percent to a Value less or equal to 80%.

6. CONTROL DIAGRAM

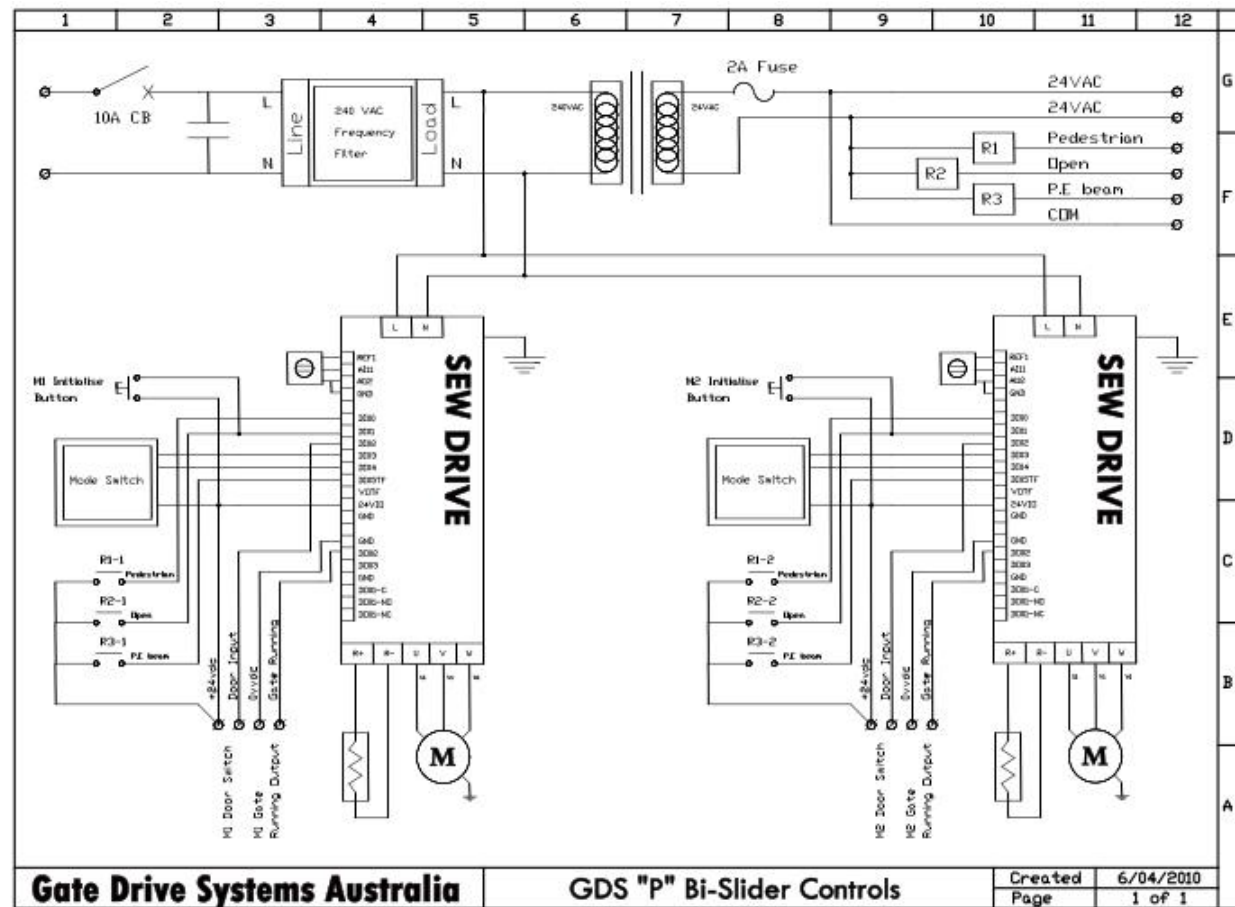
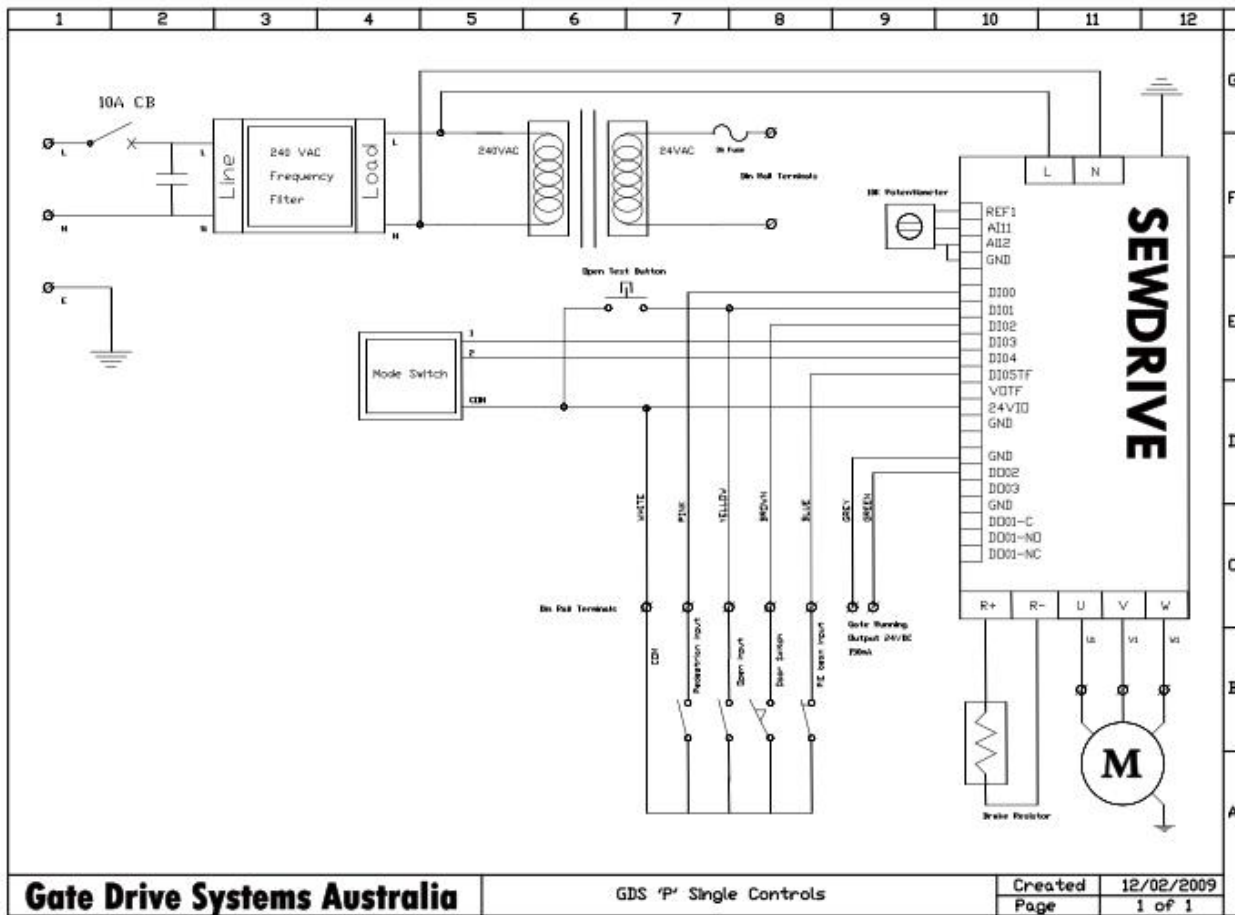

6. MANUAL RELEASE INSTRUCTIONS

Place key in door lock, turn clockwise till released and pull door open.



Turn knurled knob anticlockwise approx. $\frac{1}{2}$ a turn to release. With the clutch door open this disengages the door switch, which in turn inhibits the operation of the operator.

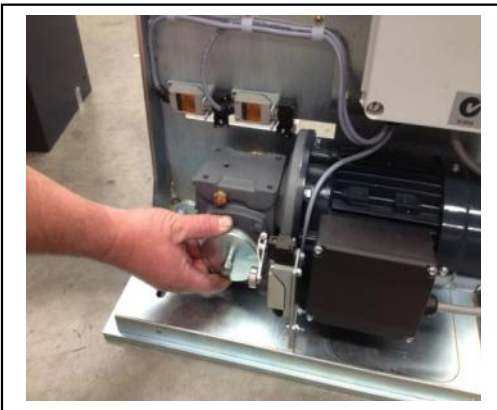

Gate can now be opened by hand.



To re-engage the clutch, move the gate by hand into approx. The half way position and turn the Knurled knob clockwise until it is very tight. If, when turning the knurled knob clockwise and it just spins, either, try spinning it clockwise with more force to release it off of the hexagonal retaining nut or hold the nut with one hand and turn the knurled knob clockwise. Once re engaged and the door is closed the inverter will need to re find its limits. Give the gate a command to open, it will start moving open slowly, once open, it will then return slowly till fully closed. Once closed, give it another open command, it will again open slow fully. Once open, it is ready for normal operation at high speed.

7. MAINTENANCE DETAILS



WARNING!

Failure to maintain equipment may result in injury or death and/or damage to property and equipment

Recommended maintenance to be performed on the operator and gate are as follows:-

Operator performs over 150 cycles a day	each month
Operator performs between 100-150 cycles a day	every 2 month
Operator performs between 50-99 cycles a day	every 4 months
Operator performs between 20-49 cycles a day	every 6 months
Operator performs under 20 cycles a day	every 12 months

Date:

Site Name:.....

Site Address:

Before commencing maintenance on the operator, isolate the electrical supply to ensure operator will not run inadvertently.

- Gate rolls freely when in manual.....
- Gate wheels and guide rollers in good condition.....
- Gate stops in good condition and not loose.....
- Gate rack is tight & correct clearances between pinion wheel & rack.....
- Gate track is not damaged.....
- Gate operator mounting bolts right.....
- No oil leaks from gearboxes.....
- Gearbox mounting bolts/nuts tight.....
- Inside operator and control box clean.....
- 'Baygon' Surface Spray around operator and control box (not on electronics).....
- All electrical connections tight.....
- Limit Switches operate in appropriate positions/ chain oiled.....
- External safety devices work effectively / cleaned.....
- Electromagnetic lock, if fitted, operates correctly and is clean.....
- Wash down of control box and cover (particularly near corrosive/sea environments)....
- General operation i.e. speed, auto close etc normal.....

Comments

.....

.....

Service performed by.....

8. WARRANTY

- a. Gate Drive Systems Australia warrants that the goods manufactured by it shall be free from defect in manufacture for a period of 12 months from the date of invoice. Should any fault occur within that period as a result of faulty workmanship or materials, Gate Drive Systems Australia at its discretion, replace the product at no charge to the Customer except for removal, installation & freight. The appropriate Serial Number must be quoted for all warranty claims.
- b. For the goods not manufactured by Gate Drive Systems Australia, we shall pass on the manufacturer`s warranty to the Customer from the date of invoice. It is the manufacturer`s discretion to repair or replace goods deemed to be defective as a result of faulty workmanship or materials.
- c. All goods must be returned to Gate Drive Systems Australia or its representative for inspection or testing to assess if a claim is justified. It is the responsibility and at the cost of the Customer, to remove & return the goods for inspection and freight costs are the responsibility of the Customer.
- d. The warranty is negated and will not apply in the following circumstances:-
 - i. If no proof of date of purchase can be produced.
 - ii. If the product has been used in a manner beyond its design parameters.
 - iii. If the product is tampered with or repaired by personnel not authorised to do so.
 - iv. In respect of loss or damage caused by rough treatment.
 - v. If the product is not used and maintained in accordance with instructions or recommendations listed in this Installation and Maintenance Manual.
 - vi. In respect of loss or damage caused by an Act of God or any other cause not within the manufacturers control.
- e. Goods returned under warranty for repair or testing will incur a charge to be fixed by the manufacturer if no fault is found.
- f. The Customer shall bear freight charges for removing & returning the goods for inspection and for the delivery & installation of any replacement or repaired product from a justified warranty claim.
- g. Save for the express conditions and warranties herein contained all other conditions or warranties (whether as the quality, fitness for purpose or any other matter) expressed or implied by statute, common law, equity, trade custom, usage or otherwise are hereby expressly excluded provided that nothing in these terms and conditions shall exclude or limit any breach or condition implied by law, the exclusion or limitation of which is not permitted by law.